

# 15头工业级超高速数码印花机

## 15-Head High Speed Industrial Digital Printing Machine

i3200-A1-15H

510m<sup>2</sup>/h

LF-1915

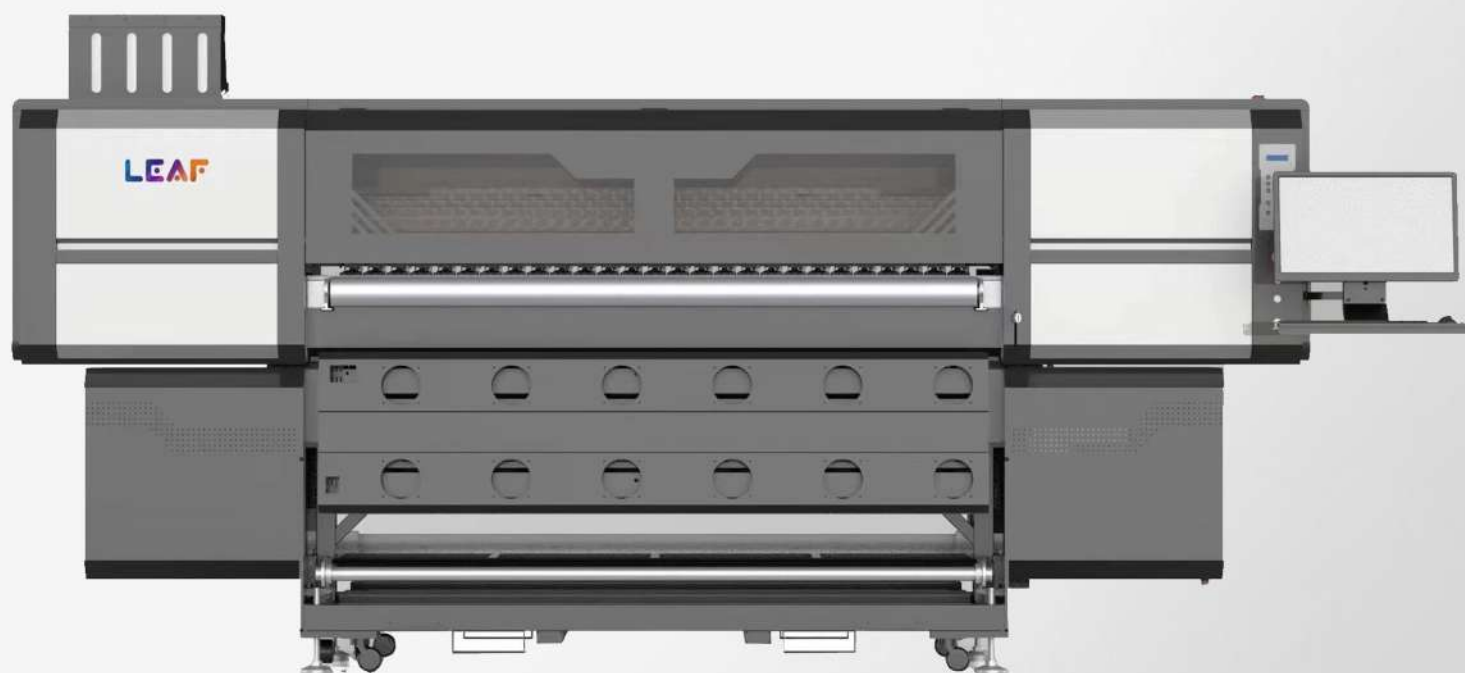

万米收送系统 (选配)  
10000m take-up and feeding system (optional)



千米收送系统 (标配)  
3000m take-up and feeding system(default)



恒温自动烘干系统  
Constant temperature automatic drying system



**Contacts**  
Aimin: 139 2225 2289

集团总部: 广州黄埔区科学大道50号绿地中央广场A3栋901室  
Group HQ: Rm.901 Bd.A3 Greenland Center Plaza of No.50 Science Avenue Huangpu Zone, Guangzhou City  
Website: www.leafprinting.io  
E-mail: Betty030318@126.com



微压电系统  
PrecisionCore



高耐久性  
High durability



多灰度输出  
Support for grey scale



高分辨率  
High resolution



皓叶国际  
Bright Leaf International

皓叶国际集团荣誉出品  
Honorably produced by Bright Leaf Int'l Group

### LF-1915 高速数码印花机

#### 产品特点

一体式重型整机钢架结构, 机身更稳固, 保证打印稳定输出。  
独家自研全铝升降墨栈, 封头更可靠, 更耐用。  
后放后收双气胀轴千米或万米收放系统, 收放稳定, 节省纸张和人力成本。  
超大功率智能烘干系统, 解决高速打印中墨量不干引起的皱纸问题。  
超大容量缺墨报警墨瓶, 保证连续供墨, 智能提醒功能, 更人性化。

#### 技术参数

| 名称          | 十五头高速数码印花机                          |
|-------------|-------------------------------------|
| 设备型号        | LF-1915                             |
| 喷头类型及数量     | I3200-A1 15pcs                      |
| 物理分辨率 (dpi) | 240×1800 / 360×1800 / 480×1800      |
| 打印宽幅        | 1.9M                                |
| 适用介质        | 热转印纸                                |
| 收纸米数        | 标准1000米                             |
| 放纸米数        | 3000米/10000米可选                      |
| 烘干系统        | 自动恒温烘干机                             |
| RIP 软件      | 标配锐印, 蒙泰, Photoprint (可选)           |
| 温度/湿度       | 温度: 20-30℃, 湿度: 45-65%              |
| 功率          | 机器功率: 1600W 前置烘干: 6000W 底部烘干: 8000W |

### LF-1915 High speed digital printer

#### Product features

Integrated heavy-duty machine steel frame structure, the body is more stable, to ensure the stable output of printing.  
Exclusive self-developed all-aluminum lifting ink station.  
Heavy duty media feeding and take up system with dual air shaft or 10,000 meters feeding and take up system. Stable, save paper and labor costs.  
Super power intelligent drying system, solve the problem of wrinkling paper caused by the ink quantity in high speed printing.  
Large capacity ink shortage alarm bottle, ensure continuous ink supply, intelligent reminder function, more humane.

#### Specifications

| Name                    | 15-head high speed digital printing mach      |
|-------------------------|---|
| Model                   | LF-1915                                       |
| Printhead and Quantity  | I3200-A1 15pcs                                |
| Resolution(dpi)         | 240×1800 / 360×1800 / 480×1800                |
| Printing width          | 1.9M  |
| Media Type              | Thermal transfer paper                        |
| Paper roll length (m)   | 1000m   |
| Feeding paper length(m) | 3000m/10000m(Optional)                        |
| Heating system          | Auto constant temperature drying system       |
| RIP Software            | RIIN,Main Top,Photoprint (Optional)           |
| Temperature/Humidity    | Temperature: 20-30℃, Humidity: 45-65%         |
| Power                   | Power: 1600W Preposition: 6000W Bottom: 8000W |

机器尺寸: L3945mm\*W1540mm\*H2025mm(3000米)  
L3945mm\*W2755mm\*H2025mm(万米)  
包装尺寸: L3990mm\*W1330mm\*H1730mm(3000米)  
万米腿包装尺寸: L2570\*W1350\*H1210mm  
净重: 1110KG(3000米) 毛重: 1200KG(3000米)  
Machine Dimension: L3945\*W1540mm\*H2025mm(3000M)  
L3945\*W2755mm\*H2025mm(Myriametre)  
Package Dimension: L3990\*W1330mm\*H1730mm(3000M)  
Package Dimension of Myriametre stand:L2570\*W1350mm\*H1210mm  
Net Weight: 1110KG (3000m) Gross Weight: 1200KG(3000m)

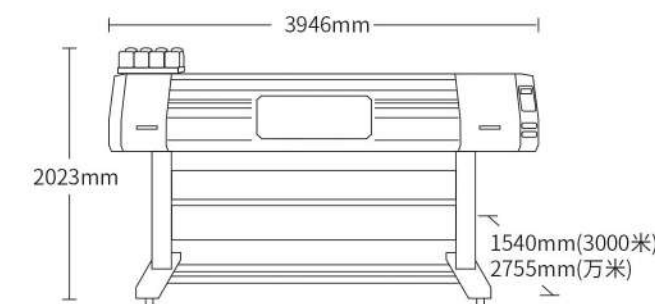

电源 Voltage  
AC220V