



12H -S3200-A1 LF-1912S

12-H High Speed Industrial Digital Printing Machine

1000m²/h
LF-1912S EPSON i3200-A1 4H



墨水循环
Ink cycle



S型设计
S style



高分辨率
High resolution



高耐久性
High durability



多灰度输出
Support for grey scale

集团总部: 广州市开发区光谱西路3号皓叶国际

Group HQ.: The 1st Floor of R&D Bld. No.3 Guangpu West Rd., Huangpu Zone, Guangzhou city, Guangdong Province PRC.
E-mail: Betty030318@126.com
Website: www.brightleafchina.com www.leafprinting.net



皓叶国际集团荣誉出品
Honorably produced by Bright Leaf Int'l Group

产品特点

采用PLC控制, 系统更加稳定, 触摸人机界面, 操作更方便, 更人性化;

自动刮墨清洗, 无纸自动停止打印, 实现无人看守; X轴运动方向采用直线电机(磁悬浮)驱动, 速度快, 噪音低, 精度更高, 更稳定;

智能换卷, 收/放卷自动定位到装卸位置; 高清/高速两种生产模式, 一键切换喷头自动清洗功能, 智能便捷操作。

技术参数

名称	十二头高速数码印花机
型号	LF-1912S
喷头型号(可选)	EPSON S3200-A1
物理分辨率(dpi)	1PASS 300×600 2PASS 300×1200
喷头数量	12
最大打印系统(色)	4-8
喷印宽度	1.9M
适用介质	转印纸/木纹纸/薄膜/墙纸
收放纸	收千米,放万米
墨水种类	热升华/水性颜料/活性
压缩空气	耗量0.03m ² /min 气压≥0.6MPA
电源	380VAC 功率16KW
RIP 软件	标配锐印, 蒙泰, Photoprint(可选)

机器尺寸 / Machine Dimension:

L4420*W2690*H1980mm

万米收放尺寸 / 10,000-meter Paper feeder System:

L2600*W1245*H1240mm

包装尺寸:

Package Dimension:

L2600*W1345mm*H1240mm(万米收放 / 10,000-meter Paper feeder System)

机器净重:
Net Weight: 1460KG

机器毛重:
Gross Weight: 1600KG

万米收放净重:
LEG PARTNet Weight: 507KG

万米收放毛重:
LEG PARTGross Weight: 580KG

Guangzhou Fire Leaf Technology Co., Ltd.

Product features

PLC and touch panel interface are applied to enable a more stable, convenient and humanized system;

Auto ink-shave, auto stop when paper runs out, man-free operation; X-axis movement direction is driven by linear motor (magnetic levitation), fast speed, low noise, higher precision and more stable.

Intelligent material roll change, the feeding and take up system automatically locates to the loading and unloading position.

Specifications

Name	12-head high speed digital printing
Model	LF-1912S
Printhead type	EPSON S3200-A1
Resolution(dpi)	1PASS 300×600 2PASS 300×1200
Printhead QTY	12
Ink Color	4-8
Max printing thickness	1.9M
Media	sublimation transfer paper/Wood grain paper/film/wallpaper
Paper roll length(M)	Take-up:1000M,Feeding:10000M
Ink type	sublimation/Dye
Compressed air	Consumption: 0.03m ² /min Air pressure : ≥0.6MPA
Power supply	380VAC Power: 16KW
RIP Software	RIIN, Main Top, Photoprint (Optional)

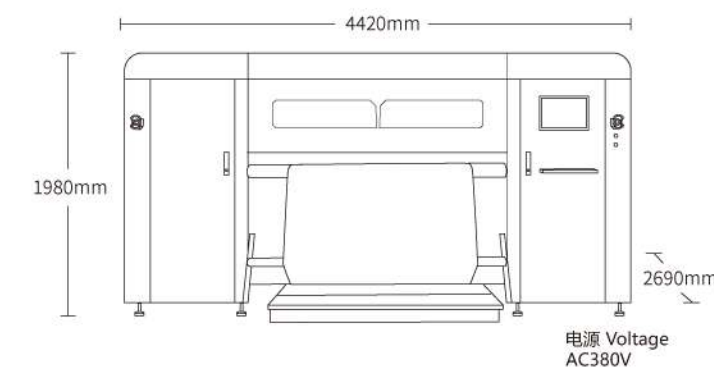

电源 Voltage
AC380V