

8头工业级超高速数码印花机

8-Head High Speed Industrial Digital Printing Machine

i3200-A1-8H

300m²/h

LF-198



标配千米收送, 选配万米
1000m take-up and feeding system(default)
10000m take-up and feeding system (optional)

静音导轨
Mute guide rail

大容量墨盒
High capacity ink cartridge

恒温自动烘干系统
Constant temperature automatic drying system



微压电系统
PrecisionCore



高耐久性
High durability



多灰度输出
Support for grey scale



高分辨率
High resolution

集团总部: 广州市开发区光谱西路3号皓叶国际
Group HQ.: The 1st Floor of R&D Bd. No.3 Guangpu West Rd., Huangpu Zone, Guangzhou city, Guangdong Province PRC.
E-mail: Betty030318@126.com
Website: www.leaf-cn.com



皓叶国际
Bright Leaf International

皓叶国际集团荣誉出品
Honorably produced by Bright Leaf Int'l Group

LF-198
高速数码印花机

产品特点

独家自研全铝升降墨栈, 封头更可靠, 更耐用。
恒温自动烘干系统, 材料受热均匀, 墨水吸附性好, 画面细腻饱满。
个性化定制, 适用于织带、烫画行业。
超大容量缺墨报警系统, 智能提醒功能, 保证连续供墨, 更人性化。
缺纸报警系统, 纸张打印完毕智能提醒, 操作更方便、安全。

技术参数

名称	八头高速数码印花机
设备型号	LF-198
喷头类型及数量	I3200-A1 8pcs
打印宽幅	1.9M
适用介质	热转印纸
烘干系统	自动恒温烘干机
RIP 软件	标配蒙泰, Neostampa, Texprint (可选)
温度/湿度	温度: 20-30°C, 湿度: 45-65%
功率	机器功率: 1300W 前部烘干: 5400W 底部烘干: 2400W

LF-198
High speed digital printer

Product features

Exclusive self-developed all aluminum ink stack, more reliable and durable head.
Auto constant temperature drying system, the material is uniformly heated, ink absorbs well and picture is delicate and full.
Personalized customization, it suit for braid and pyrography industry.
Large capacity lack of ink alarm system, intelligent reminder function, make sure continually supply ink, more humanity.
Lack of paper alarm system, paper printed intelligent reminder, more.

Specifications

Name	8-head high speed digital printing mach
Model	LF-198
Printhead and Quantity	I3200-A1 8pcs
Printing width	1.9M
Media Type	Thermal transfer paper
Heating system	Auto constant temperature drying system
RIP Software	Main Top ,Neostampa, Texprint (Optional)
Temperature/Humidity	Temperature: 20-30°C, Humidity: 45-65%
Power	Power: 1300W Front drying: 5400W Bottom drying: 2400W

机器尺寸: L3490mm*W1390mm*H1760mm
包装尺寸: L3145mm*W1190mm*H1760mm
净重: 600KG
毛重: 720KG
Machine Dimension: L3490mm*W1390mm*H1760mm
Package Dimension:L3145mm*W1190mm*H1760mm
Net Weight: 600KG
Gross Weight: 720KG

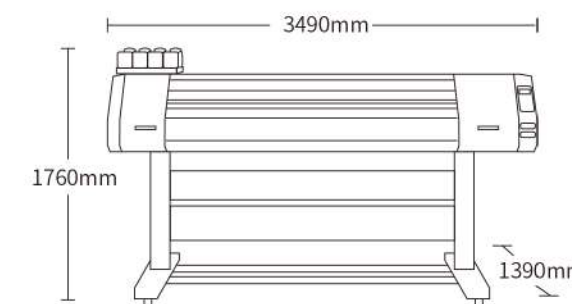

电源 Voltage
AC220V